



# CONDUCTIVE POLYMER DECOUPLING DEVICE (Proadlizer®)

CAT. No. E1001J

INDEX		
<b>PRODUCT GUIDE</b>	PRECAUTIONS AND GUIDELINES	➔
	MINIMUM ORDER QUANTITY	➔
	TAPING SPECIFICATIONS	➔
	RECOMMENDED REFLOW CONDITIONS	➔
<b>PRODUCT SPECIFICATIONS</b>	CONDUCTIVE POLYMER DECOUPLING DEVICE	➔

The Proadlizer is a Conductive Polymer Decoupling Device that uses conductive polymer electrolytic material. Please read the following in order to get the most out of your Proadlizer.

## Designing Device Circuits

### 1 Types of Circuits Where Proadlizer are Not to be Used

The leakage current in Proadlizer may vary depending on thermal stresses during soldering. Avoid the use of capacitors in the following types of circuits:

- a) High-impedance circuits that are to sustain voltages.
- b) Coupling circuits
- c) Time constant circuits

Because the capacitance varies depending on the environment the Proadlizer is used in, there is a possibility that the Proadlizer can affect a time constant circuit where sensitivity to variation in capacitance is required.

- d) Other circuits that are significantly affected by leakage current

### 2 Circuit Design

Verify the following before designing the circuit:

- a) The electrical characteristics of the Proadlizer will vary depending on differences in temperature and frequency. You had better design your after verifying the scope of these factors.
- b) When connecting two or more Proadlizer in parallel, ensure that the design takes current balancing into account.
- c) When two or more Proadlizer are connected in series, variability in applied voltage may cause over-voltage conditions. Do not use series connection for the Proadlizer.

### 3 Use in High Reliable and Critical Applications

Consult with Nippon Chemi-Con before using these Proadlizer in applications involving human life: Aviation/space equipment, Nuclear power equipment, Medical equipment and Automotive equipment, or in applications where Proadlizer failure could have a major impact.

### 4 Polarity

The Proadlizer is a polarized Conductive Polymer Decoupling Device. Do not apply either reverse voltages or AC voltages to the polarized Proadlizer, using reversed polarity may cause a short circuit. Refer to the catalog, product specifications or Proadlizer body to confirm the polarity prior to use.

### 5 Operating Voltage

Do not apply a greater than rated voltage. If a voltage greater than the rated voltage is suddenly applied, it may cause the Proadlizer failure. The peak voltage of superimposed AC voltages (ripple voltages) on DC voltages must not exceed the full rated voltage. While there are specifications for surge voltages exceeding the rated voltage, usage conditions apply, and continued operation for extended periods of time under such conditions cannot be guaranteed.

### 6 Ripple Current

Do not apply currents in excess of the rated ripple current. The superimposition of a large ripple current increases the rate of heating within the Proadlizer. When excessive ripple current is imposed the internal temperature increases which may cause the Proadlizer failure.

### 7 Operating Temperature

Use within the stated category temperature range, if used outside this range. It may cause the Proadlizer failure.

### 8 Charging and Discharging the Proadlizer

Do not use the Proadlizer in circuits where the Proadlizer is repetitively charged and discharged rapidly. Repetitively charging and discharging the Proadlizer rapidly may cause the Proadlizer failure by internal temperature increase.

### 9 Leakage current

Leakage current will increase, but it will gradually decrease if leakage current has been impressed at a temperature below the category's upper temperature limit. Additionally the self repairing action is faster when voltage near the rated voltage rather than at a higher voltage is applied at below the category's upper temperature limit.

### 10 Failure

Proadlizer failure is open mode end life failure. The open mode end life failure is shorten life by capacitance decrease and ESR increase. But over-voltage and over-current are assumed to be the short mode cause.

### 11 Proadlizer Usage Environment

Do not use/expose Proadlizer to the following conditions.

- a) Oil, water, salty water, take care to avoid storage in damp locations.
- b) Direct sunlight
- c) Toxic gases such as hydrogen, sulfide, sulfurous acids, nitrous acids, chlorine and chlorine compounds, bromine and bromine compounds, ammonia, etc.
- d) Ozone, ultraviolet rays and radiation.
- e) Severe vibration or mechanical shock conditions beyond the limits advised in the product specification section of the catalog.

### 12 Proadlizer mounting

For the surface mount Proadlizer design the copper pads on the PC board in accordance with the catalog or the product specification

## Installing Proadlizer

### 1 Installing

- a) Do not reuse Proadlizer already assembled in equipment.
- b) The Proadlizer may have self charge. If this happens, discharge the Proadlizer through a resistor of approximately 1kΩ before use.
- c) If Proadlizer are stored at a temperature of 35°C or more and more than 75%RH, the leakage current may increase. This may also occur if the Proadlizer are stored for a longer period than the period which is specified in the catalog or the product specification. In this case, they can be reformed by the voltage treatment through a resistor of approximately 1kΩ.
- d) Verify the rated capacitance and voltage of the Proadlizer when installing.
- e) Verify the polarity of the Proadlizer.
- f) Do not use the Proadlizer if they have been dropped on the floor.
- g) Do not deform the case of the Proadlizer.

- h) Do not apply excess force to the Proadlizer. Avoid subjecting the Proadlizer to strong forces, as this may break the Package, bend or deform the Proadlizer or damage the packaging, and may also cause short/open circuits, increased ESR, increased leakage current. Also, note the Proadlizer may be damaged by mechanical shocks caused by the vacuum/insertion head, component checker or centering operation of an automatic mounting or insertion machine.

## 2 Heat Resistance during Soldering

Ensure that the soldering conditions meet the specifications recommended by Nippon Chemi-Con. Note that the leakage current may increase due to thermal stresses that occur during soldering, etc. Furthermore, the leakage current which rose gradually decreases, when voltage is applied at below the category upper limit temperature. Additionally the self repairing action is faster when voltage near the rated voltage rather than at a higher voltage is applied at below the category's upper temperature limit.

- a) Verify the following when reflow soldering:
- Soldering conditions (preheat, solder temperature and soldering time) should be within the limits prescribed in the catalogs or the product specification.
  - The heat level should be appropriate. (Note that the thermal stress on the Proadlizer varies depending on the type and position of the heater in the reflow oven, and the color and material of the Proadlizer.)
  - Vapor phase soldering (VPS) is not used.
- b) Do not reuse a Proadlizer that has already been soldered to PC board and then removed. When using a new Proadlizer in the same location, remove the flux, etc. first, and then solder on the new capacitor in accordance with the specifications.

## 3 Handling After Soldering

Do not apply any mechanical stress to the Proadlizer after soldering onto the PC board.

- a) Do not use the Proadlizer for lifting or carrying the assembly board.
- b) Do not hit or poke the Proadlizer after soldering to PC board. When stacking the assembly board, be careful that other components do not touch the Proadlizer.
- c) Do not drop the assembled board.

## 4 Cleaning PC boards

Please do not wash Proadlizer.

## 5 Precautions for using adhesives and coating materials

- a) Do not use any adhesive and coating materials containing halogenated solvent.
- b) Before using the other adhesive and coating material, consult with Nippon Chemi-con.

## 6 Fumigation

In many cases when exporting or importing electronic devices, such as Proadlizer, wooden packaging is used. In order to control insects it may become necessary to fumigate the shipment. Precautions during "Fumigation" using halogenated chemical such as Methyl Bromide must be taken. Halogen gas can penetrate packaging materials such as cardboard boxes and vinyl bags. Penetration of the halogenated gas can cause corrosion of Proadlizer. Nippon Chemi-Con gives consideration to the packaging materials not to require the Fumigation. Verify whether the assembled PC board, products and Proadlizer themselves are subjected to Fumigation during their transportation or not.

## The Operation of Devices

- a) Do not touch the Proadlizer terminals directly.
- b) Do not short-circuit between anode and cathode terminal of a Proadlizer by letting it come into contact with any conductive object. Also, do not spill electric-conductive liquid such as acid or alkaline solution over the Proadlizer.
- c) Do not use Proadlizer in circumstances where they would be subject to exposure to the following materials
- Oil, water, salty water or damp location.
  - Direct sunlight.
  - Toxic gases such as hydrogen sulfide, sulfurous acid, nitrous acid, chlorine or its compounds, and ammonium.
  - Ozone, ultraviolet rays or radiation.
  - Severe vibration or mechanical shock conditions beyond the limits prescribed in the catalog or product specification.

## Maintenance Inspection

- a) Make periodic inspections of Proadlizer that have been used in industrial applications. Before inspection, turn off the power supply and carefully discharge the electricity in the Proadlizer. Verify the polarity when measuring the Proadlizer with a volt-ohm meter. And use a volt-ohm meter that measurement voltage is lower than the rated voltage of the Proadlizer. Do not apply any mechanical stress to the Proadlizer.
- b) The following items should be checked during the periodic inspections.
- Significant damage in appearance
  - Electrical characteristics: leakage current, capacitance,  $\tan\delta$  and other characteristics prescribed in the catalog or product specification.
  - We recommend replacing the Proadlizer if the parts are out of specification.

## Contingencies

- a) If gas has vented from the Proadlizer during use, there is a short circuit and burning, or the Proadlizer discharges an odor or smoke, turn off the main power supply to the equipment or unplug the power cord.
- b) If there is a problem with the Proadlizer or a fire breaks out, the Proadlizer may produce a burning gas or reactive gas from the outer resin, etc. If this happens, keep your hands and face away from the gas. If vented gas is inhaled or comes into contact with your eyes, flush your eyes immediately with water and/or gargle. If vented gas comes into contact with the skin, wash the affected area thoroughly with soap and water.

## Storage

We recommend the following conditions for storage.

- a) Store Proadlizer in a cool, dry place. Store at a temperature between 5 and 30°C, with a humidity of 70% or less.

(table-1)

	Before the bag is opened	After the bag is opened
Proadlizer	Within 2 years after manufacturing	Within 168 hours after the bag is opened

Proadlizer is sealed in a special laminated aluminum bag. Use all Proadlizer once the bag is opened. Return unused Proadlizer to the bag, and seal it with a zipper. Please refer to (Table -1) for storage conditions. Please do the baking under the following condition if the storage period passes after the bag is opened.

(Baking condition)  
Bulk : 170°C, 1H



## PRECAUTIONS AND GUIDELINES (Conductive Polymer Decoupling Device (Proadlizer®))

- b) Store the Proadlizer in a location free from direct contact with water, salt water, and oil.
- c) Store in a location where the Proadlizer is not exposed to toxic gas, such as hydrogen sulfide, sulfurous acid, nitrous acid, chlorine or chlorine compounds, bromine or other halogen gases, methyl bromide or other halogen compounds, ammonia, or similar.
- d) Store in a location where the Proadlizer is not exposed to ozone, ultraviolet radiation, or other radiation.
- e) It is recommended to store Proadlizer in their original packaging wherever possible.

### **Disposal**

Please consult with a local industrial waste disposal specialist when disposing of Proadlizer.

### **Catalogs**

Specifications in the catalogs may be subject to change without notice. The data mentioned in the catalogue are representative values, not guaranteed characteristics.

### **Regarding compliance for European REACH Regulation**

According to the content of RIP3.8TGD (Technical Guidance Document) which is published on 26 May 2008, our electronic components are "articles without any intended release". Therefore they are not applicable for "Registration" for European REACH Regulation Article 7 (1).

Reference: Electrolytic Condenser Investigation Society  
"Study of REACH Regulation in EU about Electrolytic Capacitor" (publicized on 13 March 2008)

\* "Proadlizer®" is the registration of trademark of NEC TOKIN Corporation.



## PACKAGING

---

### MINIMUM ORDER QUANTITY

Please order by minimum order quantity.

#### ◆SURFACE MOUNT

Series	Size code	Quantity (pcs)
		Taping
WR	F25	1,000
WRB	E20	1,000

## TAPING SPECIFICATIONS

### SURFACE MOUNT TYPE (TAPING)

◆CARRIER TAPE [mm]

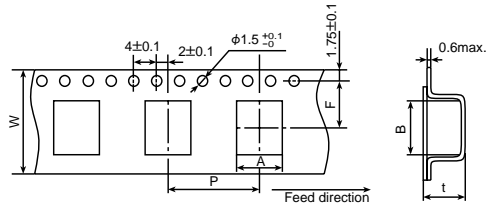

[mm]

Series	Items	W	A	B	F	P	t
		$\pm 0.3$	$\pm 0.3$	$\pm 0.3$	$\pm 0.1$	$\pm 0.1$	$\pm 0.3$
WR	F25	24.0	12.5	17.1	11.5	16.0	2.7
WRB	E20	16.0	5.7	9.0	7.5	8.0	1.9

◆ REEL DIMENSIONS [mm]

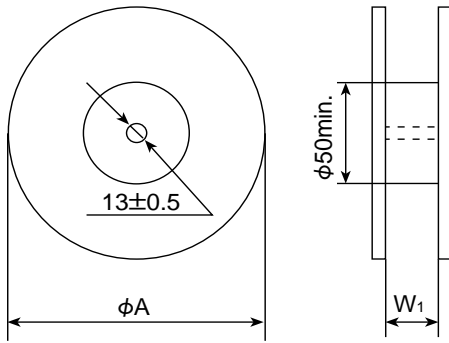

◆ QUANTITY PER REEL/BOX

Series	Size code	Quantity (pcs/reel)	W <sub>1</sub> (mm)	A (mm)
WR	F25	1,000	25.5	382 max.
WRB	E20	1,000	17	182 max.

◆ POLARITY

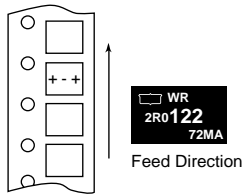

**Proadlizer®** Integrated Passive Component

◆GROUP CHART

CONDUCTIVE POLYMER DECOUPLING DEVICE

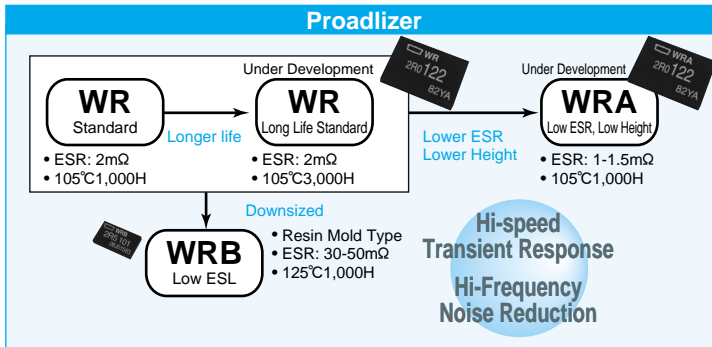

◆DIMENSIONS [mm]

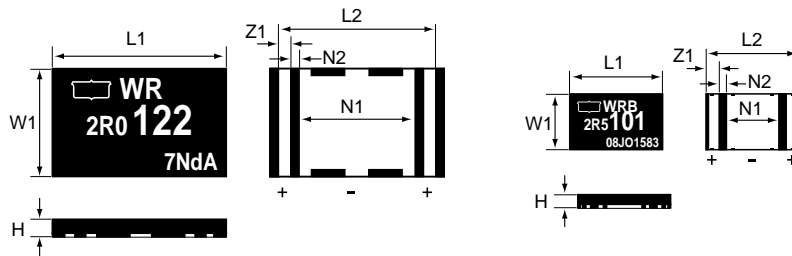

Series	Case Code	L1	L2	W1	Z1	N1	N2	H
WR	F25	16.7±0.2	15.3±0.2	12.1±0.2	1.0±0.2	10.4±0.2	1.4±0.2	2.5max.
WRB	E20	8.5±0.2	8.2±0.2	5.3±0.2	1.2±0.2	4.6±0.2	0.6±0.2	2.0max.

◆PART NUMBERING SYSTEM

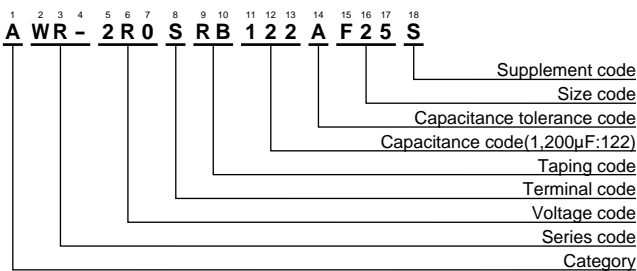

◆PRINTING

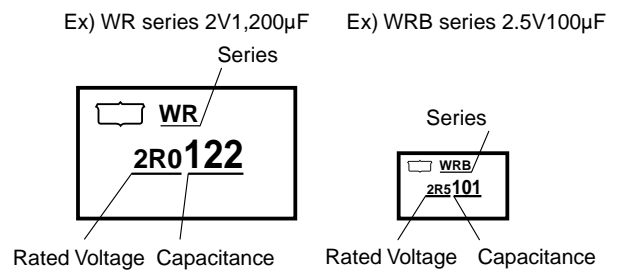

◆RECOMMENDED SOLDER LAND [mm]

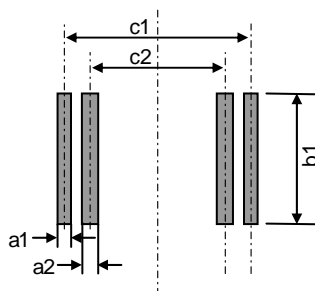

Series	Size Code	a1	a2	b1	c1	c2
WR	F25	1.6	1.8	14.2	14.8	8.4
WRB	E20	1.3	1.0	6.0	7.1	3.6

■ : Solder land

**Proadlizer®** Integrated Passive Component

◆RECOMMENDED REFLOW SOLDERING CONDITIONS

- The following conditions are recommended for air or infrared reflow soldering Proadlizer onto a glass epoxy circuit board of 220mm×50mm×1.6mm (with resist) by cream solder.
- The temperatures shown are the surface temperature values on the top of the case and temperature of Proadlizer terminal.

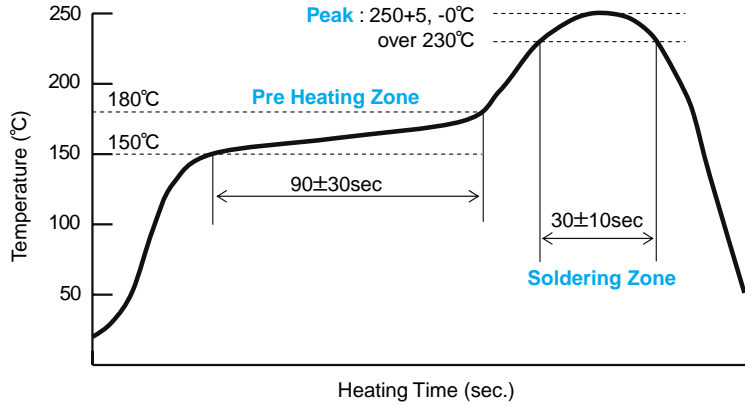

Pre Heating	Peak Temperature	Max period of time over 230°C	Max period of time over 200°C	The times of reflow soldering
150 to 180°C 90±30sec	Within 250+5, -0°C	30±10sec	50±10sec	Twice or less

◆NOTE (Reference)

- Filtering Circuit Design

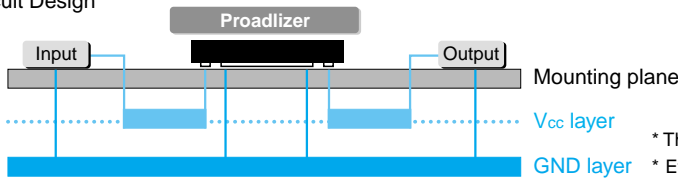

\* This circuit design is for high-frequency noise reduction.  
\* Effective "Filtering" performance is obtained by carrying out separation by the side of input and output of Vcc layer.

- Decoupling Circuit Design

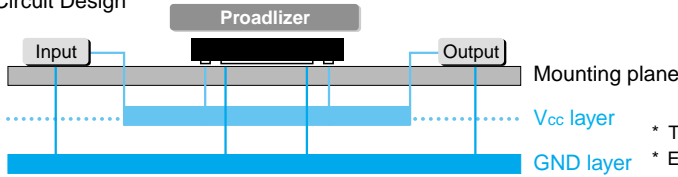

\* This circuit design is for high-speed transient response.  
\* Effective "Decoupling" performance is obtained by not carrying out separation by the side of input and output of Vcc layer.

◆PERFORMANCE (Reference)

- Impedance - Frequency

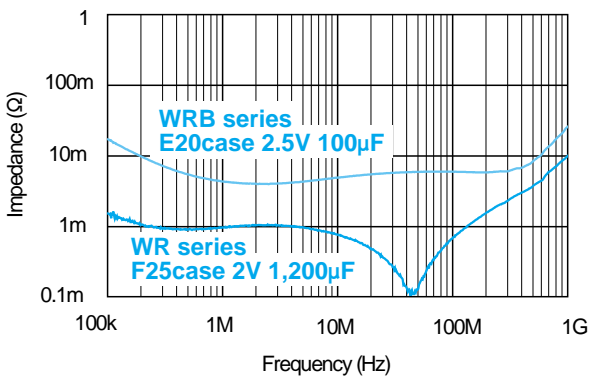

Directly measured without Substrate

- Attenuation - Frequency

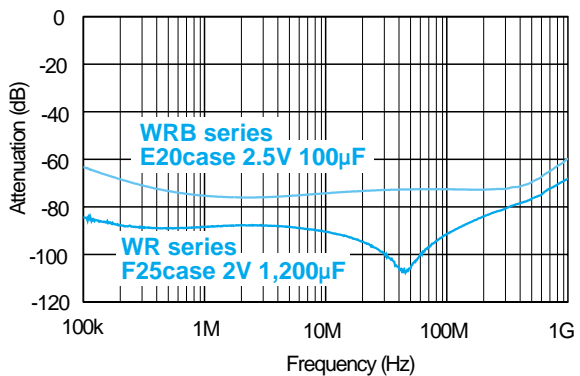

Directly measured without Substrate

"Proadlizer" is the registration of trademark of NEC TOKIN Corporation.

# Proadlizer® WR Series



*Integrated Passive Component*

- Case size : 16.7×12.1×2.5 [mm] (F25)
- Endurance : 1,000 hours at 105°C
- The function of two or more capacitors is integrated.
- Super low ESR, impedance and high heat resistance have been obtained by using conductive polymer as electrolyte.
- Excellent noise absorption performance at GHz frequency.
- Halogen Free



## ◆SPECIFICATIONS

Items	Characteristics		
<b>Category Temperature Range</b>	-55 to +105°C		
<b>Rated Voltage</b>	2V <sub>dc</sub>		
<b>Capacitance Tolerance</b>	+25% to -20% (A): 2V1,200μF ±20% (M): 2V1,000μF (at 20°C, 120Hz)		
<b>Surge Voltage</b>	Rated Voltage×1.15 (at 105°C)		
<b>Leakage Current</b>	Shall not exceed values shown in STANDARD RATINGS. (at 20°C, after 5 minutes)		
<b>Dissipation Factor (tanδ)</b>	Shall not exceed values shown in STANDARD RATINGS. (at 20°C, 120Hz)		
<b>Temperature Characteristics</b>	Temperature	at -55°C	at +105°C
	Capacitance Change	Within 0% to -20% of the initial value	Within +50% to 0% of the initial value
	DF (tanδ)	≤The initial specified value	≤150% of the initial specified value
	ESR	≤The initial specified value	≤150% of the initial specified value
	Leakage Current	≤The initial specified value	≤10 times of the initial specified value
<b>Endurance</b>	The following specifications shall be satisfied when the devices are restored to 20°C after the rated voltage is applied for 1,000 hours at 105°C.		
	Appearance	No significant damage	
	Capacitance Change	≤±20% of the initial value	
	DF (tanδ)	≤200% of the initial specified value	
	ESR	≤200% of the initial specified value	
	Leakage Current	≤The initial specified value	
<b>Humidity</b>	The following specifications shall be satisfied when the devices are restored to 20°C after exposing them for 500hours at 40°C 90 to 95%RH without voltage applied.		
	Appearance	No significant damage	
	Capacitance Change	Within +50% to -20% of the initial value	
	DF (tanδ)	≤200% of the initial specified value	
	ESR	≤200% of the initial specified value	
	Leakage Current	≤The initial specified value	
<b>Surge Voltage Test</b>	The devices shall subjected to 1,000 cycle each consisting of charge with the surge voltage specified at 105°C for 30 seconds through a protective resistor (R=1kΩ) and discharge for 5 minutes and 30 seconds, and then shall be satisfied when the devices are restored to 20°C.		
	Appearance	No significant damage	
	Capacitance Change	≤±20% of the initial value	
	DF (tanδ)	≤200% of the initial specified value	
	ESR	≤200% of the initial specified value	
	Leakage Current	≤The initial specified value	
<b>Rapid Change of Temperature (Temperature Cycle)</b>	-55°C to 105°C, 5 cycle		
	Appearance	No significant damage	
	Capacitance Change	≤±20% of the initial value	
	DF (tanδ)	≤200% of the initial specified value	
	ESR	≤200% of the initial specified value	
	Leakage Current	≤The initial specified value	

If any doubt arises, measure the leakage current after following voltage treatment.  
Voltage treatment : DC rated voltage are applied to the Proadlizer for 120 minutes at 105°C.

## ◆STANDARD RATINGS

WV [V <sub>dc</sub> ]	Cap. 20°C120Hz [μF]	Size code	tanδ 20°C120Hz	Leakage current after 5min. [μA]	ESR 20°C100kHz [mΩmax]	Rated ripple current -55 to +105°C [mArms / 100k to 300kHz]	Part No.
2	1,000	F25	0.1	300	2	5,000	AWR-2R0SRB102MF25S
2	1,200	F25	0.1	300	2	5,000	AWR-2R0SRB122AF25S

# Proadlizer® WRB Series



- 75% downsized from WR series (F25)
- Case size : 8.5×5.3×2.0 [mm] (E20)
- Endurance : 1,000 hours at 125°C
- The function of two or more capacitors is integrated.
- Super low ESR, impedance and high heat resistance have been obtained by using conductive polymer as electrolyte.
- Excellent noise absorption performance at GHz frequency.
- Halogen Free



## ◆SPECIFICATIONS

Items	Characteristics		
<b>Category Temperature Range</b>	-55 to +125°C		
<b>Rated Voltage</b>	2.5Vdc, 4Vdc		
<b>Capacitance Tolerance</b>	±20% (M) (at 20°C, 120Hz)		
<b>Surge Voltage</b>	Rated Voltage×1.15 (at 125°C)		
<b>Leakage Current</b>	Shall not exceed values shown in STANDARD RATINGS. (at 20°C, after 5 minutes)		
<b>Dissipation Factor (tanδ)</b>	Shall not exceed values shown in STANDARD RATINGS. (at 20°C, 120Hz)		
<b>Temperature Characteristics</b>	Temperature	at -55°C	at +125°C
	Capacitance Change	Within 0% to -20% of the initial value	Within +50% to 0% of the initial value
	DF (tanδ)	≤The initial specified value	≤150% of the initial specified value
	ESR	≤The initial specified value	≤150% of the initial specified value
	Leakage Current	≤The initial specified value	≤10 times of the initial specified value
<b>Endurance</b>	The following specifications shall be satisfied when the devices are restored to 20°C after the rated voltage is applied for 1,000 hours at 125°C.		
	Appearance	No significant damage	
	Capacitance Change	≤±20% of the initial value	
	DF (tanδ)	≤200% of the initial specified value	
	ESR	≤200% of the initial specified value	
<b>Humidity</b>	The following specifications shall be satisfied when the devices are restored to 20°C after exposing them for 500hours at 65°C 90 to 95%RH without voltage applied.		
	Appearance	No significant damage	
	Capacitance Change	Within +30% to -20% of the initial value	
	DF (tanδ)	≤200% of the initial specified value	
	ESR	≤200% of the initial specified value	
<b>Surge Voltage Test</b>	The devices shall subjected to 1,000 cycle each consisting of charge with the surge voltage specified at 125°C for 30 seconds through a protective resistor (R=1kΩ) and discharge for 5 minutes and 30 seconds, and then shall be satisfied when the devices are restored to 20°C.		
	Appearance	No significant damage	
	Capacitance Change	≤±20% of the initial value	
	DF (tanδ)	≤200% of the initial specified value	
	ESR	≤200% of the initial specified value	
<b>Rapid Change of Temperature (Temperature Cycle)</b>	-55°C to 125°C, 5 cycle		
	Appearance	No significant damage	
	Capacitance Change	≤±20% of the initial value	
	DF (tanδ)	≤200% of the initial specified value	
	ESR	≤200% of the initial specified value	
	Leakage Current ≤The initial specified value		

If any doubt arises, measure the leakage current after following voltage treatment.  
Voltage treatment : DC rated voltage are applied to the Proadlizer for 120 minutes at 125°C.

## ◆STANDARD RATINGS

VV [Vdc]	Cap. 20°C120Hz [μF]	Size code	tanδ 20°C120Hz	Leakage current after 5min. [μA]	ESR 20°C100kHz [mΩmax]	Rated ripple current -55 to +125°C [mArms / 100k to 300kHz]	Part No.
2.5	33	E20	0.05	42	50	2,000	AWRB2R5SRB330ME20P
2.5	100	E20	0.05	125	30	2,800	AWRB2R5SRB101ME20P
4	22	E20	0.05	44	50	2,000	AWRB4R0SRB220ME20P
4	47	E20	0.05	94	30	2,800	AWRB4R0SRB470ME20P